

GEOHERMAL LOOP PUMP MODULE

GEO-FLO **COMMERCIAL 3/4HP**

FEATURES

Powerful Grundfos CR4-20U centrifugal pump

Full-flow 1" brass valves

Fully assembled and leak tested

Compatible with all brands

Standard 1-1/4" NPT connections

All components easily serviceable

Reliable operation

Compact attractive design



1-YEAR WARRANTY
PARTS & LABOR

GEO-FLO PRODUCTS CORPORATION

905 Williams Park Drive, Bedford Indiana 47421 Bus (800)784-8069 Fax (812)275-8523
Manufacturers of quality geothermal loop pump modules and accessories since 1988

Operation:

When the geothermal system is operating, the module pump energizes and circulates the liquid solution through the geothermal heat pump and the earth loop, enabling the heat transfer process to occur.

Installation:

The Commercial series loop pump modules are designed for quick and easy installation. Each module can be floor mounted using the convenient mounting holes provided.

All external liquid connections are standard 1-1/4" NPT to accommodate standard fittings.

Filling and flushing of the heat pump and earth loop is accomplished through the side connections. The two brass valves rotate to four different positions to direct flow in the desired manner. Step by step instructions are included in an installation manual packaged with each module.

Note: Check local codes for specific installation requirements.

Specifications:

Minimum Valve Bore: 1.00"
 Pump: Grundfos CR4-20U
 Piping Connections: 1-1/4" NPT

Power Requirements:

Standard 115/208-230 VAC 1 Ph 60 Hz
 Optional 208-230/460 VAC 3 Ph 60 Hz

Approved Liquid Solutions:

Methanol
 Propylene Glycol

Maximum Operating Pressure: 150 PSI
 Minimum Operating Temperature: 20 F
 Maximum Operating Temperature: 120 F

Weight: 106 Lbs

PERFORMANCE MODEL 3/4 HP

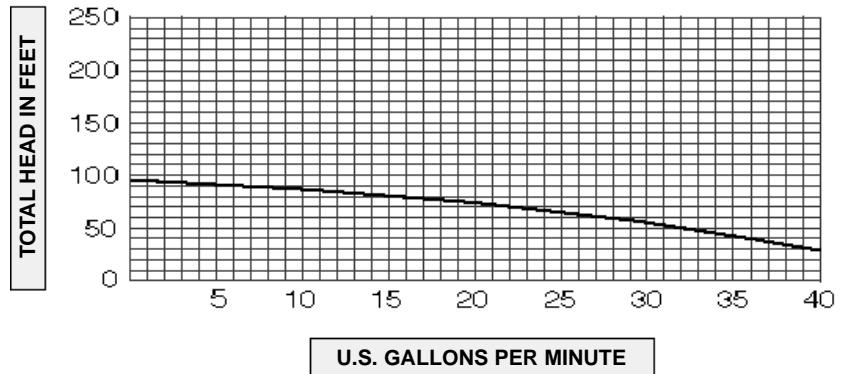

Pump End



Side

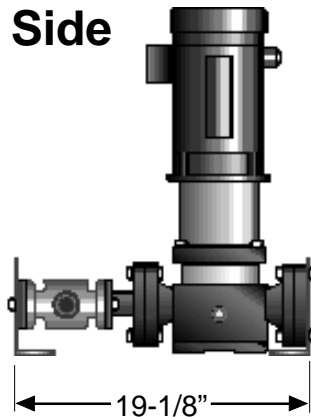

Valve End

